

TRUSS LIFTING POINTS

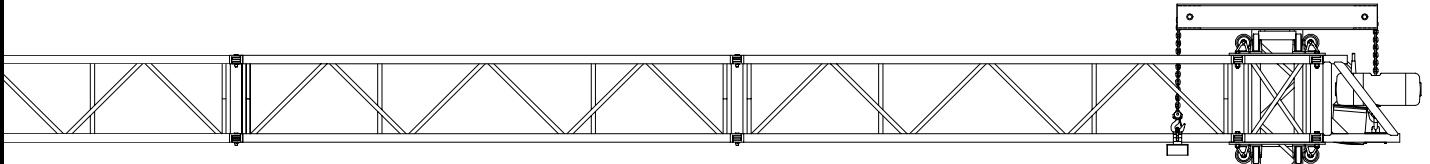

Truss Lifting Points are designed to provide a "hard" attachment to trusses as an alternative to synthetic round slings. The Lifting Points are designed to be attached under the bottom or top chords of a truss. Lifting Points are rated for 2000 pounds and available for 12", 15", 18", 20.5" and 30" Pre-rigged truss. Custom Lifting Points are also available.

PRODUCT CODE	DESCRIPTION
B1212	Lifting Point for 12" Truss
B2312	Lifting Point for 18" Truss
B1512	Lifting Point for 15" Truss
B1312	Lifting Point for 20.5" Truss
B1413	Lifting Point for 30" Pre-rigged Truss

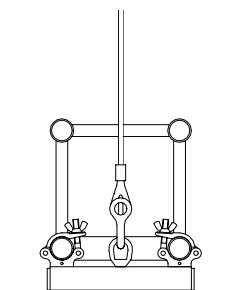
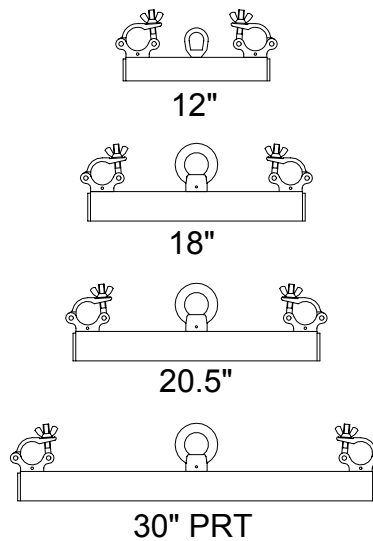

12" Lifting Point mounted to bottom chords

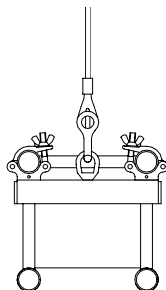

12" Lifting Point mounted to top chords

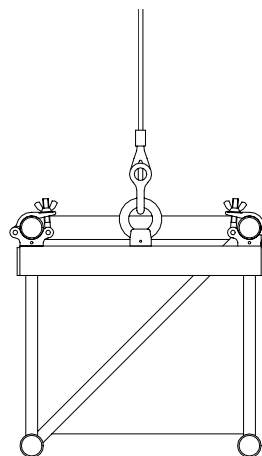

20.5" Lifting Point mounted to top chords

